

Tank wagons for Gasoline and light Oil Products

Model	15-1547-03	15-1443-06	15-1500	15-1725	15-1727	15-1754	15-1755
Carrying capacity, i.e.	66,0	66,0	125,0	67,0	66,0	68.5	67.5
Tare, t	27.3	25,8	50.8	26.0	27.5	25,0	25,8
The speed of the structural, km/h	120	120	120	120	120	120	120
Gauge	1-BM	02-BM	1-T	02-BM	02-BM	02-BM	1-BM
In 273mm(depth), mm	3260	3090	3260	3116	3112	1480	3260
H (height), mm	4636	4620	5254	4620	4610	416258	4636
The amount of the boiler, m. cube.	85.6	73.1	161,6	95.0	94,0	79,2	87,0
The diameter of the boiler, mm	422364	3000	422364	3000	3000	3060	422364
The pressure in the boiler, .6mpa	0.15	0.15	0.15	0.15	0.15	0.15	0.15
Method of filling							
Way to discharge							
Material boiler	09G2s-13	09G2s-13	09G2s-13	09G2s-14	09G2s-14	09G2s-14	09G2s-14

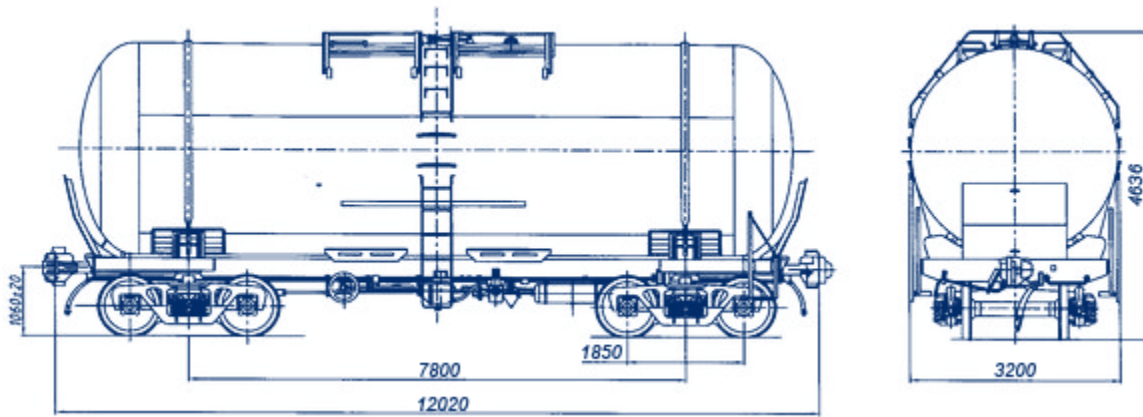

Tank wagon for gasoline and other light oil products model 15-1547-03

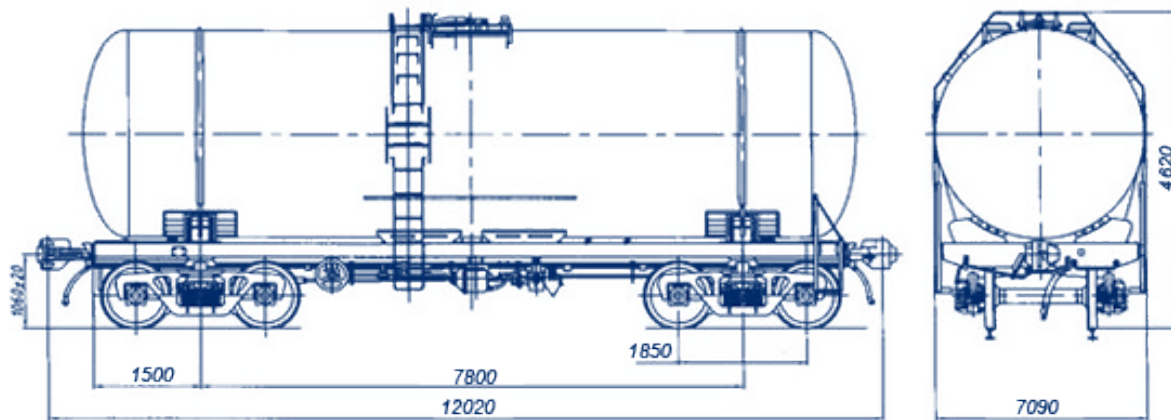

Tank wagon for gasoline and other light oil products model 15-1343-06