

Tankwagons for viscous oil products

| Model | 15-1566-07 | 15-1566-06 | T.-1710 |
|-------------------------------------|------------|------------|-----------|
| Carrying capacity, i.e. | 65,0 | 66,0 | 54,50 |
| Tare, t | 27.3 | 27.0 | 25.1 |
| The speed of the structural, km/h | 120 | 120 | 100 |
| Gauge | 02-BM | 02-BM | UIC 505-3 |
| In 273mm(depth), mm | 3090 | 3090 | No.3070 a |
| H (height), mm | 4620 | 4620 | 4,250 |
| The amount of the boiler, m. cube. | 71.7 | 73.1 | 62.7 |
| The diameter of the boiler, mm | 3000 | 3000 | 2800 |
| The pressure in the boiler, .6mpa | 0.15 | 0.15 | 0.15 |
| Method of loading and discharge | | | |
| Loading | | | |
| Plums | | | |
| Material boiler | 09G2s-13 | 09G2s-13 | 09G2s-12 |
| IKA. Temp., thermal fluid grad with | 180 | 110 | 180 |
| Track, mm | 60440 | 60440 | 1435 |

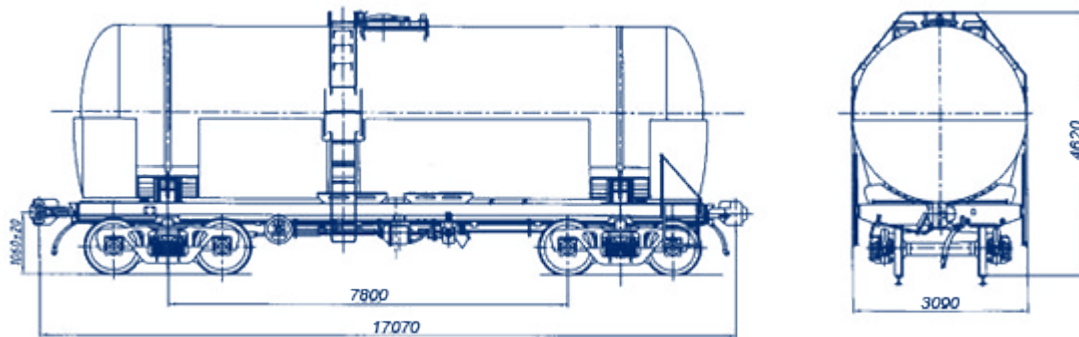

Tank wagon for viscous oil model 15-1566-06

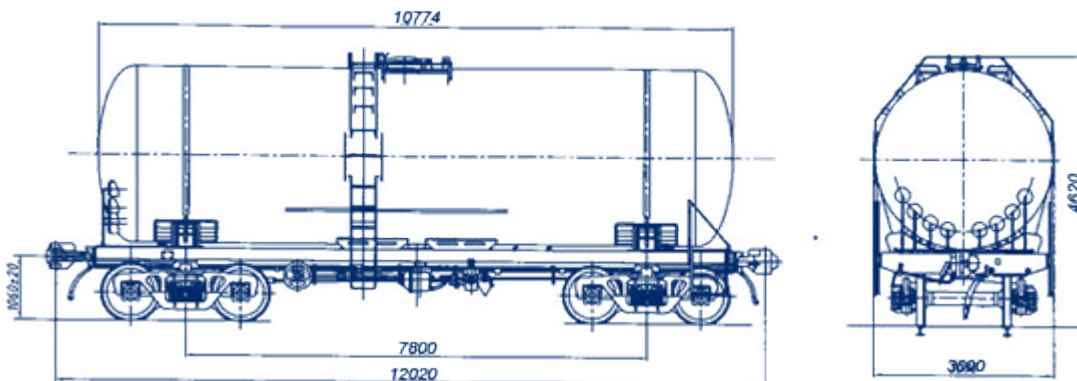

Tank wagon for viscous oil model 15-1566-07