

# Casting crane capacity of 100 +20 t

Casting crane capacity of 100 +20 t intended for reception of melting in the bucket, followed by casting molten metal into molds, as well as other lifting and transportation operations with cargo weighing up to 100 tons

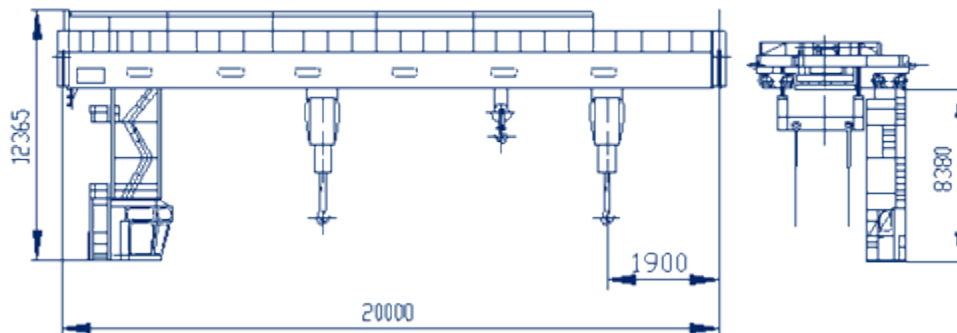

## Specifications

<b>Cranes, t:</b>	
<b>main trolley</b>	100
<b>auxiliary trolley</b>	20
<b>Number of trucks, pc</b>	2
<b>Lifting height, m</b>	
<b>main trolley</b>	18
<b>auxiliary trolley</b>	20
<b>Lifting speed, m / min</b>	
<b>main trolley</b>	4.62 / 2.35
<b>auxiliary trolley</b>	14.23
<b>Travel speed, m / min</b>	
<b>Crane</b>	65.7
<b>main trolley</b>	37.48
<b>auxiliary trolley</b>	42.83
<b>Supply voltage electrical network, in</b>	Lane. 500